

HEAT C 2g L 80.52.31.01 (21)

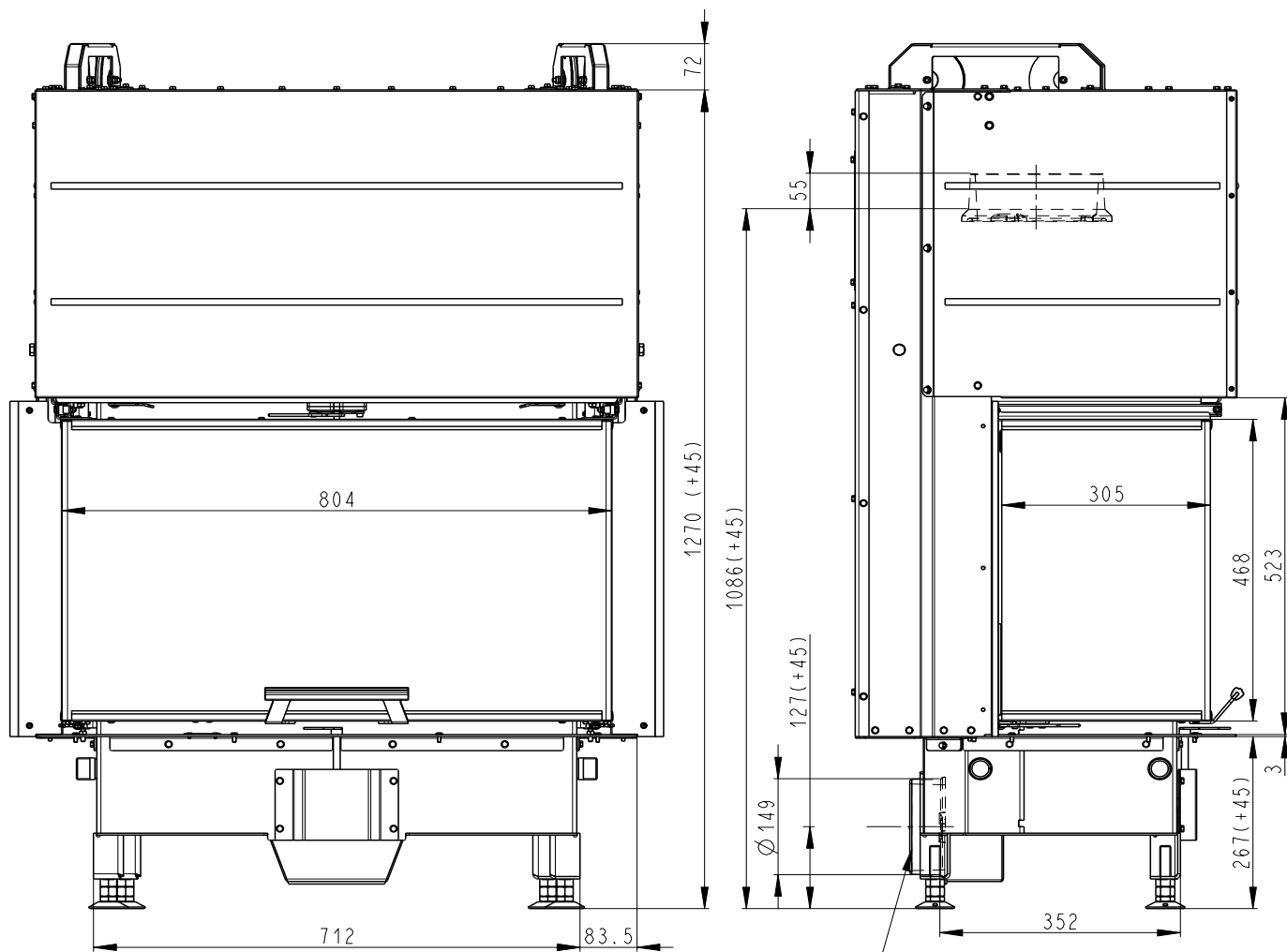

Centralni privod vzduchu
 Central air inlet
 Zentralluftzufuhr

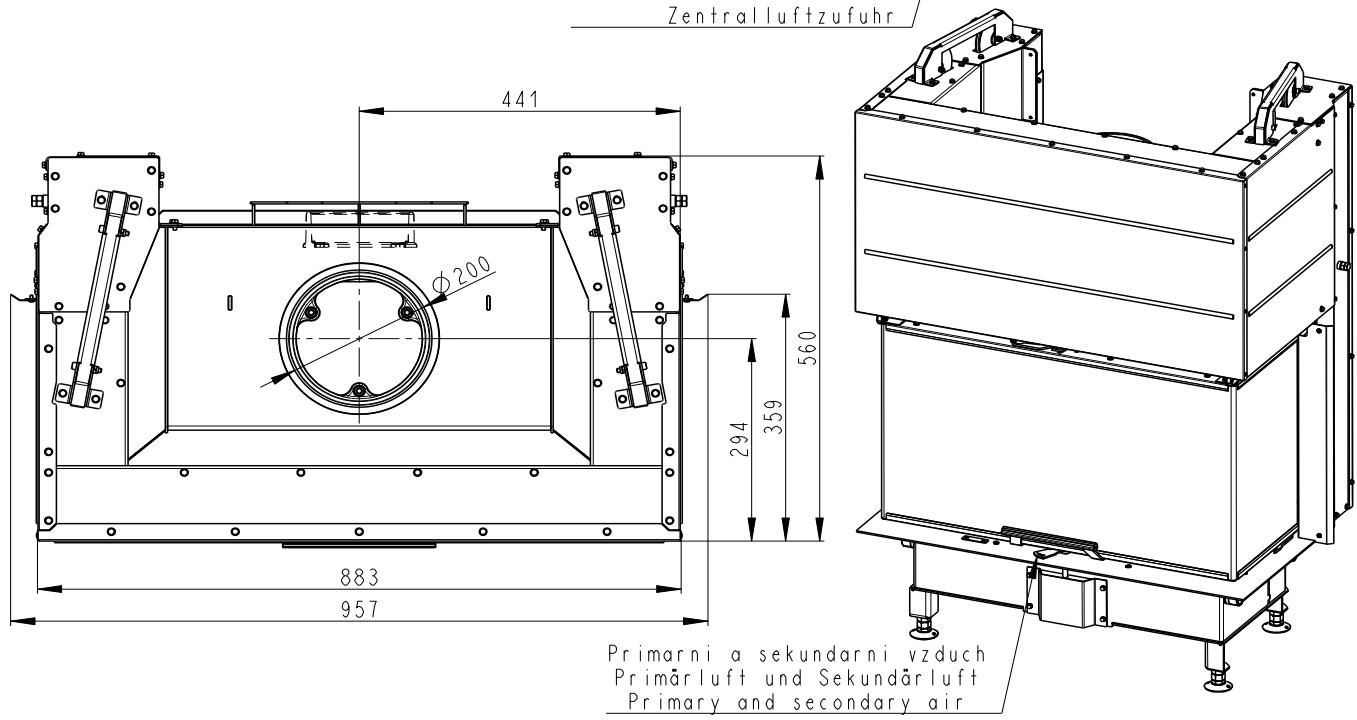

Primarni a sekundarni vzduch
 Primärluft und Sekundärluft
 Primary and secondary air

Artikl	HC2LJ 01 (21)
--------	---------------

General data

Nominal heat output	kW	9,9
Efficiency	%	80,42
Mass of the test fuel fired hourly	kg/h	2,8
Dry flue gases mass flow	g/s	8,2
Mean flue gas temperature	°C	268
Flue draught	Pa	11
Weight	kg	245
CO ₂	%	10,15

Recommended values

Reg.output	kW	5 – 13
Max. mass of the test fuel fired hourly	kg/h	4,51
Min. cross section of convect air inlet for nominal output	cm ²	900
Min. cross section of convect air outlet for nominal output	cm ²	1070
Combustion air requirement	m ³ /h	23,6
Flue gas connector diameter	mm	150 - 200

Meets requirement limit values for

EN 13 229	•
BImSch V 1	•
BImSch V 2	•
DIN plus	•
15a B-VG	•

Supplied accessories

Holder with magnet	•
Hook to open the ashtray	-
Ashtray	-

HEAT C 2g L 80.52.31.01 (21) K1

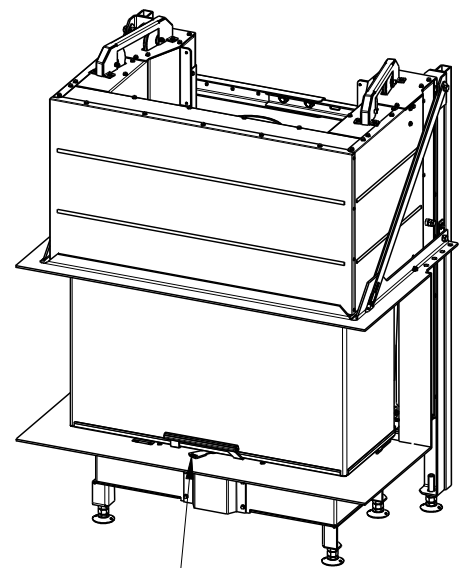
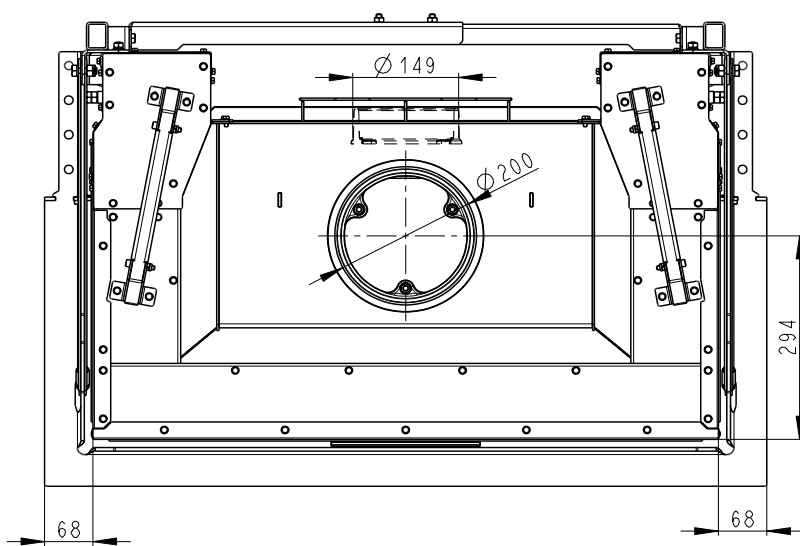
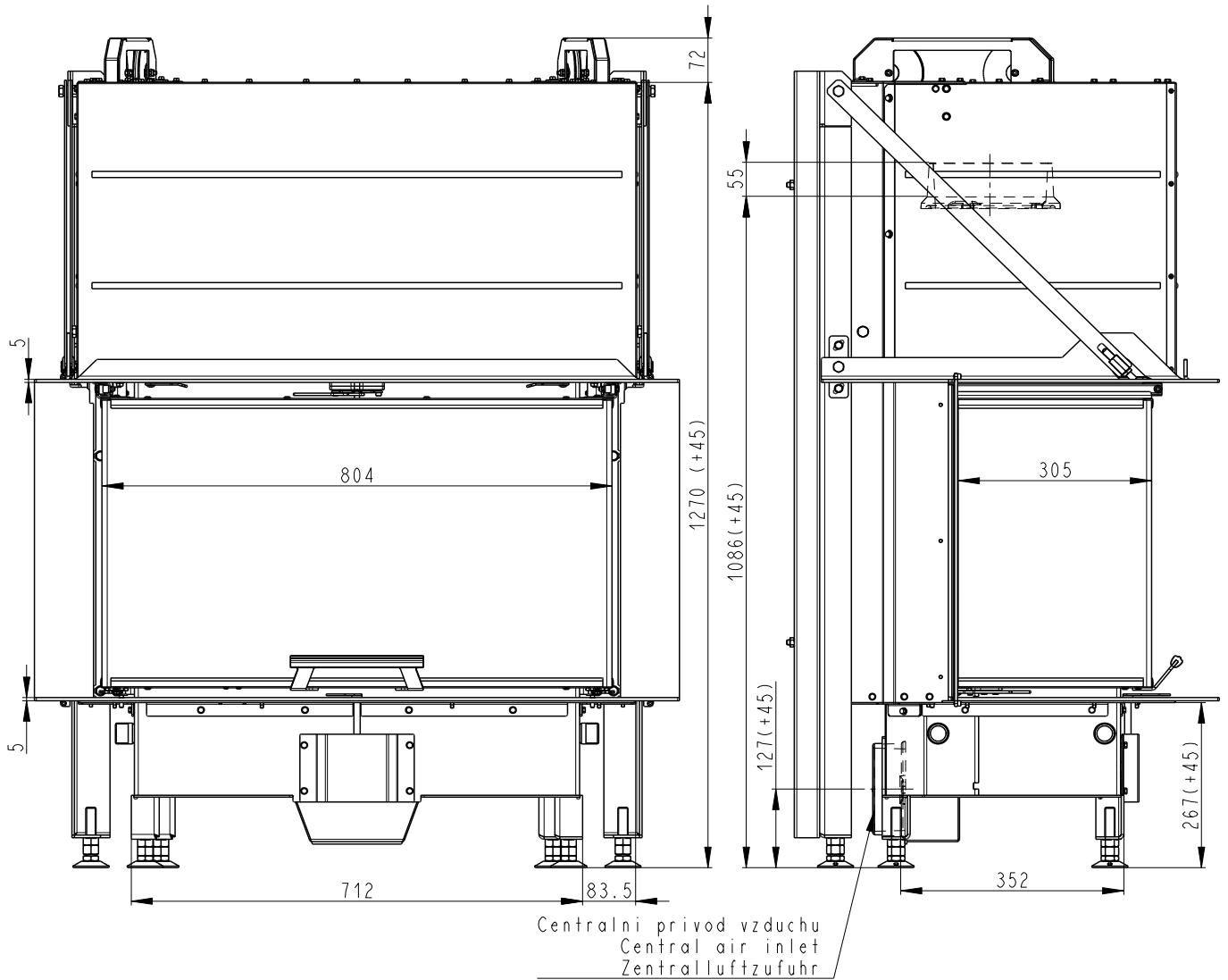

Primarni a sekundarni vzduch
 Primärluft und Sekundärluft
 Primary and secondary air

Artikl	HC2LJ 01 (21) K1
--------	------------------

General data

Nominal heat output	kW	9,9
Efficiency	%	80,42
Mass of the test fuel fired hourly	kg/h	2,8
Dry flue gases mass flow	g/s	8,2
Mean flue gas temperature	°C	268
Flue draught	Pa	11
Weight	kg	284
CO ₂	%	10,15

Recommended values

Reg.output	kW	5 – 13
Max. mass of the test fuel fired hourly	kg/h	4,51
Min. cross section of convect air inlet for nominal output	cm ²	900
Min. cross section of convect air outlet for nominal output	cm ²	1070
Combustion air requirement	m ³ /h	23,6
Flue gas connector diameter	mm	150 - 200

Meets requirement limit values for

EN 13 229	•
BImSch V 1	•
BImSch V 2	•
DIN plus	•
15a B-VG	•

Supplied accessories

Holder with magnet	•
Hook to open the ashtray	-
Ashtray	-